

•
•
•
•
•
•
•
•

Department Of Consumer Protection

Commissioner Michelle Seagull



INVESTIGATIONS DIVISION

Director

Pamela M. Brown

Supervising Inspector

Janita M. Hamel

-
-
-

DCP Overview

- Mission
 - Protect Connecticut's Marketplace
- Overview
 - \$13,000,000 Budget; 250 Employees
- Programs
 - Drug Control, Food & Standards, Liquor Control, Trade Practices, Licensing, Occupational & Professional, Registrations – HIC, NHC, Charities and Special Revenue – Lottery and Raffles, Complaint Center, Frauds
- Operations
 - Licensing, Inspections, Investigations, Enforcement, Referrals and Public Education

-
-
-

Occupational and Professional Licensing

- Annually issues about 192,000 occupational and professional licenses in 200 different categories
- Establishes and maintains high performance standards
- Administers occupational and professional licensing boards and commissions
- Continuing Education for Electricians and Plumbers and Home Inspectors
- Ensures that the people who wire your homes, fix your plumbing, sell your house or design buildings are qualified to do so.

Occupational and Professional Enforcement Unit

- Inspections: Random, complaint requested
- State, Federal, Municipal Projects
- Investigations: Complaints
- Consumer, Third Party, Anonymous, Building Official, Police, Fire Marshal, States Attorney
- Education and Compliance
- Continuing Education (electricians & plumbers)
- Chapter 393 and the Regulations
- Additional Chapters 394 & 482

Occupational Licenses Available

UNLIMITED & LIMITED

are issued to the person that passed the exam – NOT the company!

- Contractor licenses = odd #s 1,3,5,7,9
- Journeyperson licenses = even #s 2,4,6,8,10
- Heating, Cooling, Sheet metal, duct work
- Plumbing, Lawn Irrigation, Gasoline Dispensing
- Well Drilling
- Well Pumps & Water Conditioning
- Welding – steam/chill water/gas piping
- Electrical: high voltage; low voltage fire alarms & security
- Photovoltaic – Solar Electric
- Fire Protection – sprinkler systems water, foam, chemical
- Elevators, chair & stair lifts

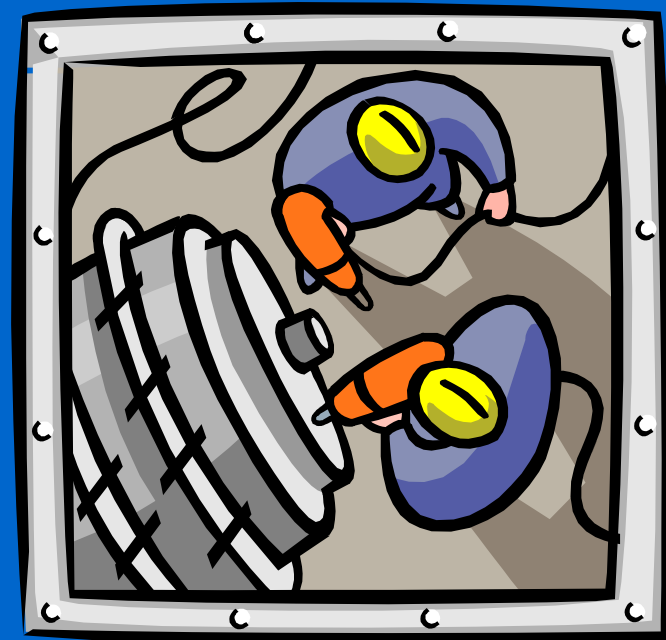

-
-
-

Additional Licenses Available

- Data and Telecommunication
- T-1,T,2; C-5,C-6
- Antennas; Satellite Dishes and Cell Phone Towers
- V-7,V-6; V-5,V-4
- TV and Radio Electronics
- V-1, V-2;
- Car: alarms, stereos, remote starters
- Neon Signs / electric signs
- Spa & Pool Repair & Maintenance SP-1, SP-2
- Conveyors, Overhead cranes/hoists
- Glazier – flat glass FG-1, FG-2; automotive glass AG-1, AG-2
- Public Service Technicians
- Telephone and Gas = PST

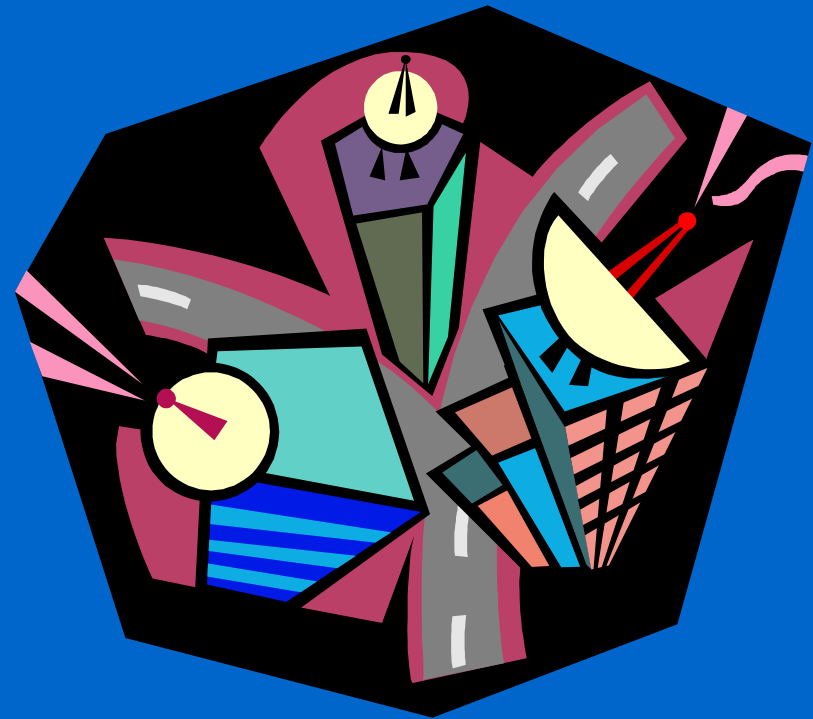

Professional Licenses



- Architects
- Landscape Architects
- Land Surveyors
- Engineers
- Civil, Mechanical, Electrical
- Fire Sprinkler Layout Technicians
- Home Inspectors
- Major Contractors
- Interior Designers
- Locksmiths
- Health Clubs
- Mobile Home Parks

-
-
-

Electrical Sign and Outline Lighting Licenses

- **C-7 LIMITED ELECTRICAL SIGN CONTRACTOR**
- **SCOPE OF WORK:**
- The holder of this license may perform only work limited to installing, servicing, maintaining and testing electric signs where such work commences at a dedicated outlet receptacle or connection directly adjacent to such sign. The requirements to qualify for this license examination shall be two (2) years as a properly licensed journeyman or equivalent experience and training.

-
-
-

Electrical Sign and Outline Lighting Licenses

- **C-8 LIMITED ELECTRICAL SIGN JOURNEYPERSON**
- **SCOPE OF WORK:**
- The holder of this license may perform only work limited to installing, servicing, maintaining and testing electric signs where such work commences at a dedicated outlet receptacle or connection directly adjacent to such sign and only while in the employ of a contractor licensed for such work. The requirements to qualify for this license examination shall be the completion of a registered apprenticeship program or equivalent experience and training.
- E-1 Unlimited Electrical Contractor and E-2 Unlimited Electrical Journeyman

-
-
-

Radon Water Mitigation Plumbing Licenses Required

- **J-1 LIMITED WELL PUMPS CONTRACTOR**
- **SCOPE OF WORK:**
- The holder of this license may perform only work limited to domestic water pumps and water conditioning. The requirements to qualify for this license examination shall be two (2) years as a journey person or equivalent experience and training.

-
-
-

Radon Water Mitigation Plumbing Licenses Required

- **J-2 LIMITED WELL PUMPS AND PIPING JOURNEYPERSON**
- **SCOPE OF WORK:**
- The holder of this license may perform only work limited to domestic water pumps and water conditioning and only while in the employ of a contractor licensed for such work. The requirements to qualify for this license examination shall be the completion of a registered apprenticeship program or equivalent experience and training.
- P-1 Unlimited Plumbing Contractor and P-2 Unlimited Plumbing Journeyman

-
-
-

Conveyor Equipment Installations

- **R-7 LIMITED CONVEYOR CONTRACTOR**
- **SCOPE OF WORK:**
- The holder of this license may perform only work limited to installation, maintenance, alteration or repair of equipment, apparatus or machines used to convey materials. Such conveyors shall be permanently or temporarily placed and of a fixed nature.
- The holder of this license may not perform work on any freight elevator.
- The requirements to qualify for this license examination shall be two (2) years as a properly licensed journeyman or equivalent experience and training.

-
-
-

Conveyor Equipment Installations

- **R-8 LIMITED CONVEYOR JOURNEYPERSON**
- **SCOPE OF WORK:**
- The holder of this license may perform only work limited to installation, maintenance, alteration or repair of equipment, apparatus or machines used to convey materials and only while in the employ of a contractor licensed for such work. Such conveyors shall be permanently or temporarily placed and of a fixed nature. The holder of this license may not perform work on any freight elevator.
- The requirements to qualify for this license examination shall be the completion of a registered apprenticeship program or equivalent experience and training.
- R-1 Unlimited Elevator Contractor and R-2 Unlimited Elevator Journeyman

-
-
-

Conveyor System

- Sample



-
-
-

Lawn Irrigation Limited Plumbing Licenses

- J-3 Contractor-limited to lawn sprinkler work.
- The requirements for this license shall be two (2) years as a journeyperson or equivalent experience and training. This license permits the installation, repair, replacement, alteration or maintenance of lawn sprinklers systems.
- J-4 Journeyperson-limited to lawn sprinkler work.
- The requirements for this license shall be the completion of a registered one-year apprenticeship program or equivalent experience and training. This license permits the installation, repair, replacement, alteration or maintenance of lawn sprinkler systems only while the licensee is in the employ of a plumbing contractor licensed for such work.

-
-
-

Lawn Sprinkler Systems

- "Lawn Sprinkler System" A lawn sprinkler system is a network of tubing or pipes with lawn sprinkler heads or lawn nozzles attached for spraying water over any and all areas which are ornamentally planted, including but not limited to turf, ground covers, flowers, shrubs, trees and similar plant materials. Control devices used in lawn sprinkler systems may consist of mechanically, hydraulically and/or electronically controlled valves and irrigation controllers.
- The installation, repair, replacement, alteration or maintenance of lawn sprinkler systems does not include (1) connections to a potable water supply; (2) the installation, repair and replacement of back-flow prevention devices; and (3) irrigation systems used for agricultural purposes.



-
-
-

Lawn Sprinkler Systems

- Back flow prevention devices installed by P-1 Unlimited Plumbing Contractors and their P-2 unlimited Plumbing Journeypeople employees.
- The installation, repair, replacement, alteration or maintenance of lawn sprinkler systems does include (1) the connection made to a preexisting backflow prevention device; and (2) the installation, replacement or maintenance of low-voltage wiring used within the lawn sprinkler system not exceeding 24 volts, providing that such wiring shall be energized only from a plug-in type controller, or a hard wired 110 volt controller that is installed and serviced by a properly licensed electrician.

-
-
-

Fire Protection Systems

- “Fire protection sprinkler systems work” means the layout, on-site fabrication, installation, alteration, maintenance or repair of any automatic or manual sprinkler system designed for the protection of the interior or exterior of a building or structure from fire, or any piping or tubing and appurtenances and equipment pertaining to such system including overhead and underground water mains, fire hydrants and hydrant mains, standpipes and hose connections to sprinkler systems, sprinkler tank heaters excluding electrical wiring, air lines and thermal systems used in connection with sprinkler and alarm systems connected thereto, ...
- but does not include (A) any engineering design work connected with the layout of fire protection sprinkler systems, or (B) any work performed by employees of or contractors hired by a public water system, as defined in subsection (a) of section 25-33d;



-
-
-

Fire Sprinkler Licenses

- **F-1 UNLIMITED CONTRACTOR (FIRE SPRINKLER)**
- **SCOPE OF WORK**
- The holder of this license may do all fire protection sprinkler system work as defined in section 20-330 of the Connecticut General Statutes.
- A person must have served at least two years as an F-2 journeyman or have equivalent experience to qualify for the F-1 examination.

-
-
-

Fire Sprinkler Licenses

- **F-2 UNLIMITED JOURNEYPERSON (FIRE SPRINKLER)**
- **SCOPE OF WORK**
- The holder of this license may do all fire protection sprinkler system work as defined in section 20-330 of the Connecticut General Statutes, but only while in the employ of a contractor licensed for such work.
- A person must have completed a 4-year fire protection sprinkler apprentice program or have equivalent experience to qualify for the F-2 examination.

Fire Protection Sprinkler

Sample

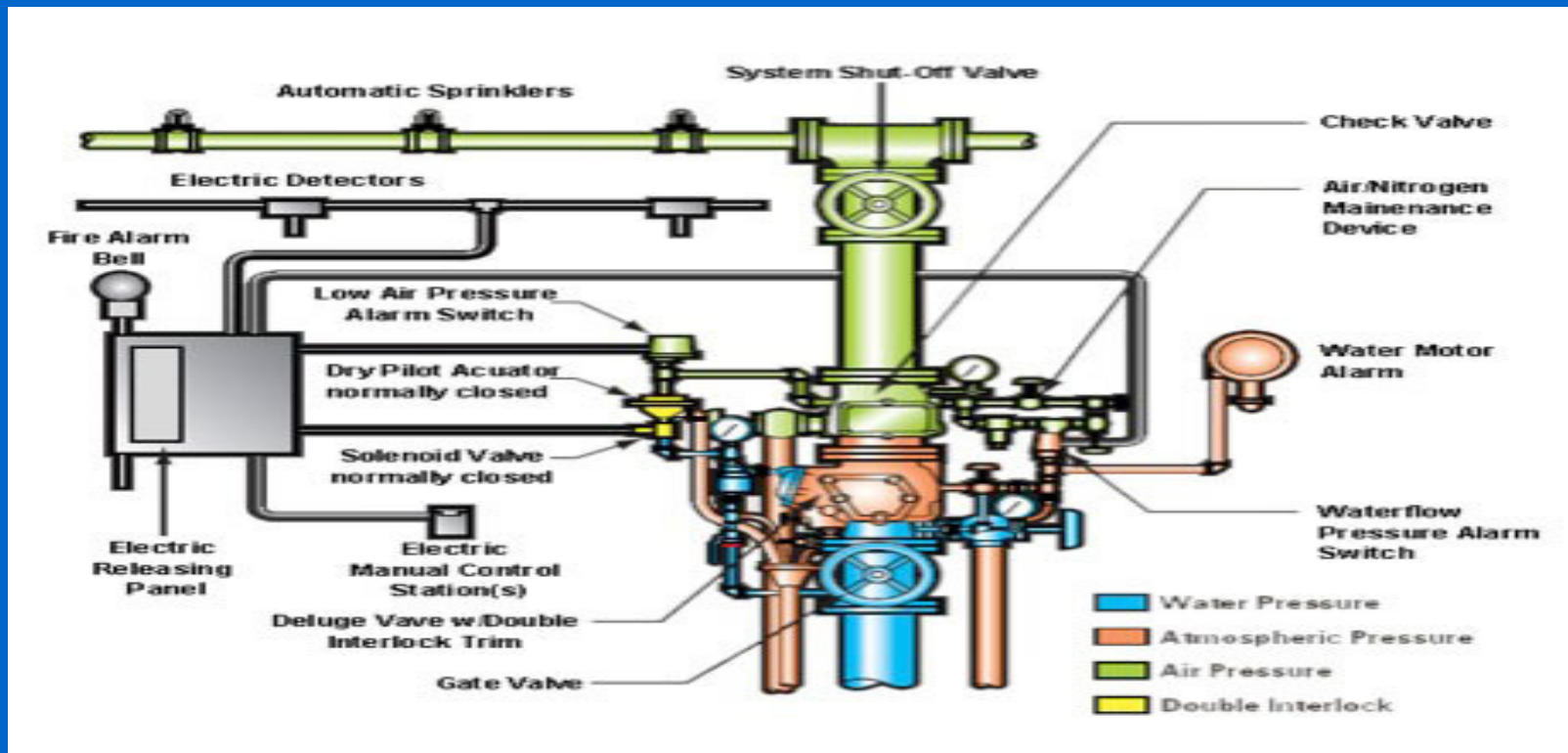

-
-
-

Fire Suppression System Licenses

- F-3 Limited fire protection contractor's license
- SCOPE OF WORK
- The holder of this license may do such work as that work involved with foam extinguishing systems, special hazard systems including water spray, foam, carbon dioxide or dry chemical systems, halon and other liquid or gas fire suppression systems.
- A person must have served at least two years as an F-4 journey person or have equivalent experience to qualify for the F-3 examination.

-
-
-

Fire Suppression System Licenses

- F-4 Limited fire protection journey person's license
- SCOPE OF WORK
- The holder of this license may do such work as that work involved with foam extinguishing systems, special hazard systems including water spray, foam, carbon dioxide or dry chemical systems, halon and other liquid or gas fire suppression systems but only while in the employ of a contractor licensed for such work.
- A person must have completed a 3-year fire protection non-sprinkler apprenticeship program or have equivalent experience to qualify for the F-4 examination.
- F-1 Unlimited Fire Sprinkler Contractor and F-2 Unlimited Fire Sprinkler Journey person

Fire Suppression System

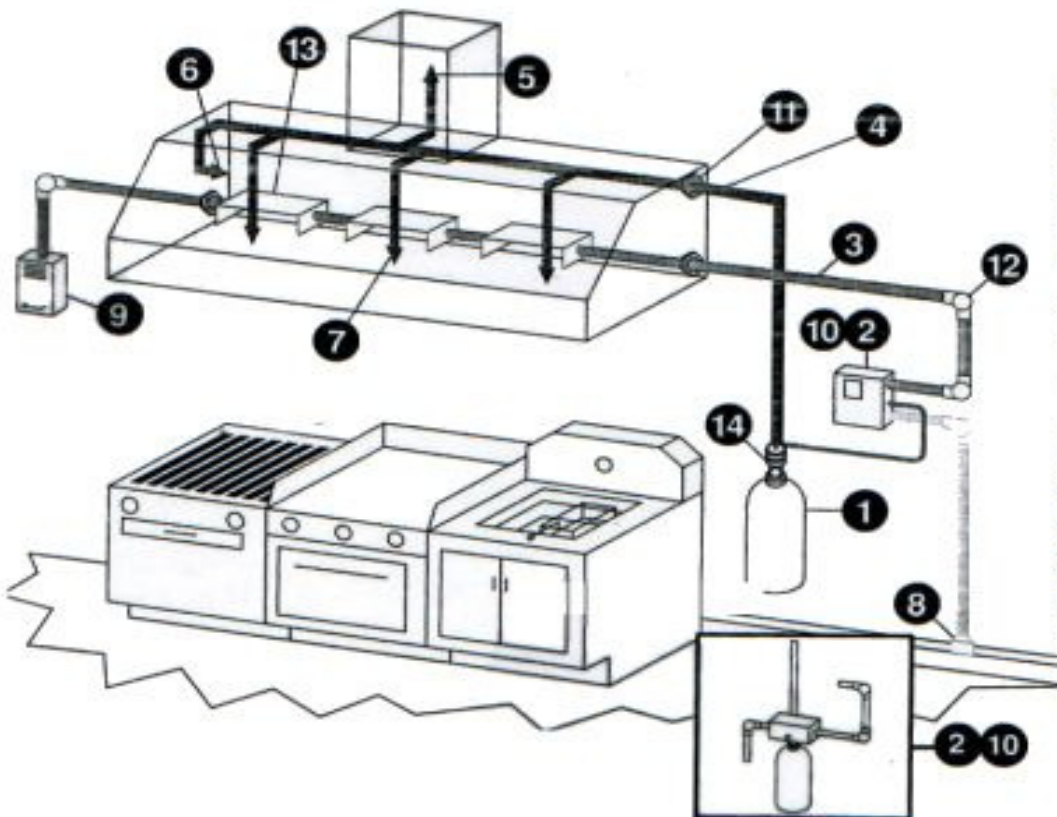

- 1 System Cylinder with Mounting Bracket
- 2 A+ Control Head or Mechanical Control Head
- 3 Detection Line Enclosed in Conduit
- 4 System Discharge Piping
- 5 Duct Nozzle
- 6 Plenum Nozzle
- 7 Appliance Nozzle (stationary or swivel)
- 8 Automatic Gas Shutoff (electrical or mechanical)
- 9 Remote Manual (Optional) recessed or surface
- 10 Electric Micro Switches (Optional)
- 11 Liquid Seal Device for Hood & Duct Penetrations
- 12 Corner Pulley for Change in Directions
- 13 Detector with Fusible Element
- 14 Pneumatic Control Head

-
-
-

GAS SUPPLY, STORAGE, PIPING AND EQUIPMENT Limited Heating and Cooling Licenses

- **G-1 LIMITED NATURAL AND LP GAS CONTRACTOR**
- **SCOPE OF WORK :**
- The holder of this license may perform only that work for the installation, repair, replacement, alteration, and maintenance of gas piping systems and approved gas appliances, gas utilization equipment and accessories for use with LP gas supplied by gas containers and/or natural gas.
- The requirements to qualify for this license examination shall be two (2) years as a properly licensed journeyperson or equivalent experience and training.

•
•
•

GAS SUPPLY, STORAGE, PIPING AND EQUIPMENT Limited Heating and Cooling Licenses

- **G-2 LIMITED NATURAL & LP-GAS JOURNEYPERSON**
- **SCOPE OF WORK:** The holder of this license may perform said work only while in the employ of a contractor licensed for such work. The holder of this license may perform only that work for the installation, repair, replacement, alteration, and maintenance of gas piping systems and approved gas appliances, gas utilization equipment and accessories for use with LP gas supplied by gas containers and/or natural gas.
- The requirements to qualify for this license examination shall be the completion of a registered apprenticeship program or equivalent experience and training (72 hour gas safety course).

-
-
-

GAS SUPPLY, STORAGE, PIPING AND EQUIPMENT

Limited Heating and Cooling Licenses

- **HPG-1 CONTRACTOR - “HEARTH PRODUCT WORK”**
- **SCOPE OF WORK:**
- The holder of this license may perform only work limited to "Hearth product work" means the installation, service or repair of a propane or natural gas fired fireplace, fireplace insert, stove or log set and associated venting and piping that simulates a flame of a solid fuel fire.
- "Gas hearth product work" does not include (A) fuel piping work, (B) the servicing of fuel piping, or (C) work associated with pressure regulating devices, except for appliances gas valves. And shall include accessories for use with LP gas supplied by gas containers and/or natural gas. The requirements to qualify for this license shall be two (2) years as a properly licensed journeyman and the presentation of a Certificate Contractor course and examination in *Hearth gas products and examination in State specific Business and law.*

-
-
-

GAS SUPPLY, STORAGE, PIPING AND EQUIPMENT Limited Heating and Cooling Licenses

- **HPG-2 JOURNEYPERSON -“HEARTH PRODUCT WORK”**
 - **SCOPE OF WORK:**
 - The holder of this license may perform only work as limited to "Hearth product work" means the installation, service or repair of a propane or natural gas fired fireplace, fireplace insert, stove or log set and associated venting and piping that simulates a flame of a solid fuel fire and only while in the employ of a licensed contractor.
 - "Gas hearth product work" does not include (A) fuel piping work, (B) the servicing of fuel piping, or (C) work associated with pressure regulating devices, except for appliances gas valves. And shall include accessories for use with LP gas supplied by gas containers and/or natural gas. The requirements to qualify for this license exam shall be the completion of at least five (500) hours of in field experience and factory training and examination in *Hearth gas products administered by this agency.*
- -
 -
 -
 -
 -
 -
 -

-
-
-

Solar Energy Work

- **PV-1 LIMITED SOLAR ELECTRIC CONTRACTOR**
- **SCOPE OF WORK**
- The holder of this license may perform only work limited to Solar Electric systems; which means the installation, erection, repair, replacement, alteration or maintenance of photovoltaic or wind generation systems, including storage and distribution of such energy for heat, light, power or other purposes to a point immediately inside a structure or adjacent to an end use.
- The requirements to qualify for this license examination shall be two years as a solar journeyman or equivalent experience and training.

-
-
-

Solar Energy Work

- **PV-2 LIMITED SOLAR ELECTRIC JOURNEYPERSON**
- **SCOPE OF WORK**
- The holder of this license may perform only work limited to Solar Electric systems; which means the installation, erection, repair, replacement, alteration or maintenance of photovoltaic or wind generation systems, including storage and distribution of such energy for heat, light, power or other purposes to a point immediately inside a structure or adjacent to an end use and only while in the employ of a licensed electrical contractor.
- The requirements to qualify for this license examination shall be the completion of a registered apprenticeship program or equivalent experience and training.
- E-1 Unlimited Electrical Contractor and E-2 Unlimited Electrical Journeyperson

-
-
-

Solar Energy Work

- * **Clarification:** The Electrical Work Examining Board has clarified “to a point inside a structure or adjacent to an end use” by unanimous vote, that a **PV-1 or PV-2 license holder is not permitted to connect to any existing panel, junction box, wiring or circuit(s) on the premises.**
- They are limited to properly terminating their wiring into a junction box or controller of theirs that is not in any way connected to the buildings existing electrical system or utility meter. Connection to the buildings existing electrical system or utility meter can only be performed by a licensed E-1 or E-2 license holder.

Site Inspections

- Heating, Cooling & Piping
- Sheet Metal & Duct Work
- Plumbing & Piping
- Welding
- Electrical & Solar Photovoltaic
- Fire Protection & Kitchen Hood Suppression Systems
- Elevators, Stair Lifts & Conveyor Systems
- Flat Glass – Glaziers
- Major Contractors
- Architects; Engineers



-
-
-

Inspector on site

- Checks for licenses of all occupational trades & professional trades working on site
- Checks company vehicles & business cards for contractor of record license number
- Checks for subcontractors list from General Contractor or Construction Manager
- Checks job trailer for posted permits
- Checks for DOL apprenticeship cards
- Issues Notice of Inspection – often as a receipt requesting information
- Checks for proper “JOBSITE” ratio
 - One to One = one licensee to one DOL registered apprentice

-
-
-

Important Information

- Sec. 20-338c. *Work not to commence until permit obtained*
- Service Changes – Cut and Reconnect
- *Contact Eversource (CL&P) for Request for Electric Service Form*
- Code Disputes with Local Building Departments
- Contact State Building Official
- *The State Building Official is the only authority to make code interpretations or modifications*

•
•
•

Violations

- Unlicensed and or unregistered
- Incompetent and or negligent workmanship
- Contractor “Selling License”
- No permits
- or permits with code violations
- Unethical Conduct
- Misrepresentation
- Beyond the scope
- Failure to complete continuing ed

• • • • • • • •

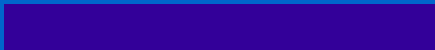
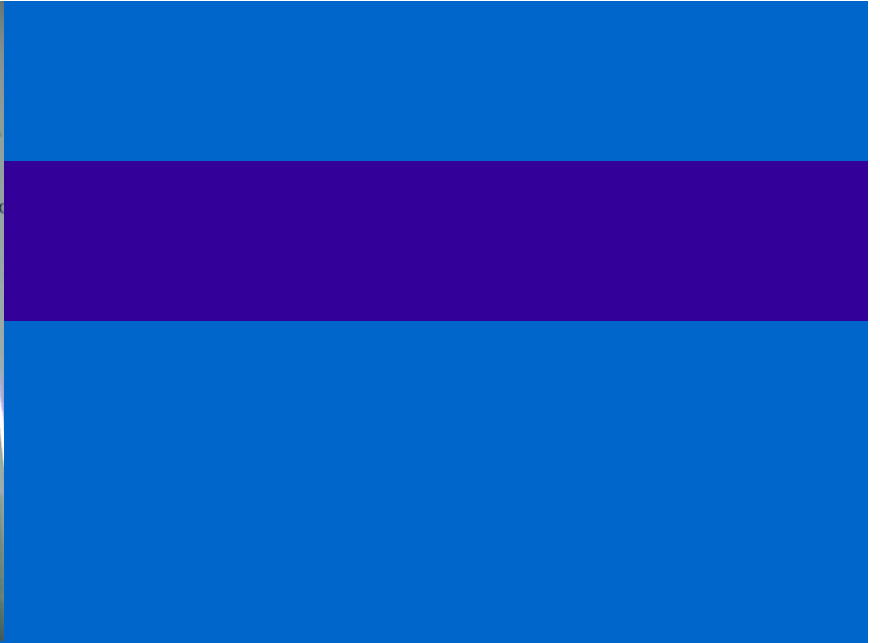
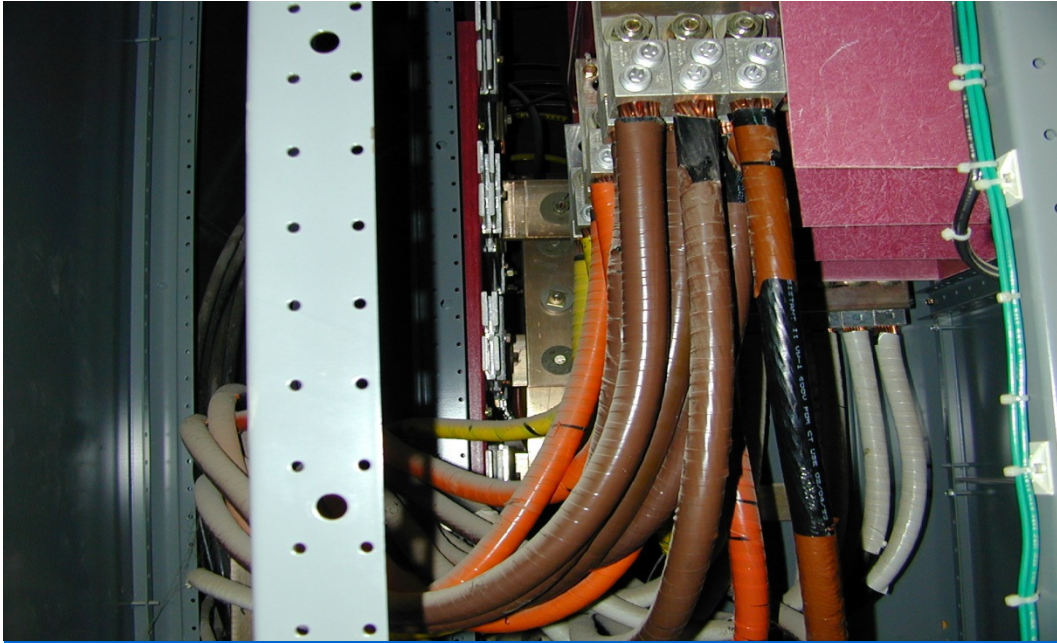

-
-
-

Enforcement Actions Available

- Incident Report is written of investigation or inspection
- Submitted for Director/Supervisory Review
- If violations are substantiated - Forwarded to DCP Legal
- Possible Compliance Meeting
- Possible Administrative Hearing – repeaters, code violations, unlicensed
 - Final Decisions and Orders
 - Civil Penalties - \$1000, \$1500, \$3000
 - Action on Licensees License – probation, suspension, revocation
- Final decisions and orders could be forwarded to the States Attorney's Office for review and possible prosecution

•
•
•

Enforcement Actions Available

- Assurance of Voluntary Compliance –
- Educational & Compliance Outreach Conducted
- Voluntarily signs agreement
 - Assures DCP they now know, understand and will follow all statutes and regulations for occupational work
 - Submits civil penalty with signed AVC
 - Accepted and Signed by Commissioner of DCP

-
-
-

New CRIMINAL Sanctions

- On 10/01/07 – NEW LAW TOOK EFFECT – IMMEDIATELY
 - From PA 07-188 to Chapter 393 Sec. 20-341
- Any person who willfully employs or supplies for employment or who willfully engages in any occupational trade work without a license or apprenticeship card shall be guilty of a class B misdemeanor ...
 - YOU CAN BE ARRESTED



-
-
-

Criminal Violations

- Sec. 29-254a: Penalty for violation of State Building Codes
 - Any person who violates any provision of the State Building Code shall be fined not less than \$200.00 nor more than \$1000.00 or imprisoned more than 6 months or both
- Sec. 53a-63: Reckless Endangerment in the 1st degree
 - Class A Misdemeanor
- Sec. 53a-63: Reckless Endangerment in the 2nd degree
 - Class B Misdemeanor
- Sec. 35-1(a): Trade Name Violations
 - Any person who violates this provision shall be fined not more than \$500.00 or imprisoned not more than one year.

Criminal Penalties

- Exploitation of the Elderly
- Larceny 2/nd degree 53-123(5)
- Class C Felony
- In REM Proceedings
 - Seize Vehicles & Equipment used in commission of a felony
- Class C Felony SOL 5 years
 - victim disabled or > 60 yoa
 - 1 - 10 years prison
- Unclassified Misdemeanor HSSA 90 days or \$500.00

-
-
-

Engineers

- Chapter 391, C. G. S. Sec.20-302 Requirements for licensure-No person shall practice or offer to practice the profession of engineering in any of its branches, including land surveying, or use any title or description tending to convey the impression that such person is a professional engineer or land surveyor, unless such person has been licensed or is exempt under the provisions of this chapter.

-
-
-

Architects

- Chapter 390, C.G.S. Sec. 20-290 Use of the title “architect”-In order to safe guard life, health and property, no person shall practice architecture in this state, except as provided in this chapter, or use the title “architect”, or display or use any words, letters, figures, title, sign, seal, advertisement or other device to indicate that such person practices or offers to practice architecture unless such person has obtained a license as provided in this chapter.

-
-
-

Engineers – Architects: Penalties

- Chapter 391 Engineers, C. G. S. Sec. 20-310
Penalty-Any person who knowingly or willfully violates any provision of this chapter shall be fined not more than \$500 or be imprisoned not more that 3 months or both.
- Chapter 390 Architects, C. G. S. Sec. 20-297
Penalty-Any person who knowingly, willfully or intentionally violates any provision of this chapter shall be fined not more than \$500 or imprisoned not more than one year or both be fined and imprisoned.

-
-
-

Websites and Telephone Numbers

- Department of Consumer Protection
- www.ct.gov/dcp
- Investigations Division (860) 713-6180
- Applications & Licensing Unit (860) 713-6135
- Department of Labor – Apprenticeship
- www.ct.gov/dol
- Testing Service
- www.psiexams.com or (800) 733-9267
- Department of Public Safety - Office of State Building Official
- www.ct.gov/dps or (860) 713-5900

•
•
•

Department of Consumer Protection Website

- www.ct.gov/dcp
- Check for Licenses
- Check for Complaints
- Download Laws and Regulations
- Download Complaint Forms
- Download Board Minutes
- Download Press Releases